



XRT Combi System Installation and Operators Manual



7.6KW – 32KW Westerbeke Diesel Generator Platform

Version: 2.06



Table of Content

Introduction.....	4
Pump I.D. & Hose Runs to Open Center Valve.....	5
Valve location	
Hose location	
Hose Specifications.....	12
Fluid Specifications.....	13
Hydraulic fluid Reservoir Tank & Filter.....	15
Open Center Valve.....	17
Installation Check List.....	21
System Test.....	22
Maintenance Guide.....	23
Certificate of Warranty.....	24
Contact Information.....	25

MANUFACTURED BY:

XRT Power Systems
A division of Hansen Marine Engineering, Inc.
32 Tioga Way
Marblehead, MA 01945

Introduction:

The **XRT Hydraulic Pump System** is a dual level hydraulic pump designed to operate one, two or three hydraulic extrication tools at the same time. Each pump circuit has two pumps assigned providing a total of 6 possible pumps for three circuits. Each individual circuit is completed with a control block assembly and an open center valve. The XRT system provides rescue personnel the ability to operate 3 extrication tools simultaneously, independent of each other, in order to implement a rapid rescue attempt.

XRT Power Systems manufactures models for both low-pressure systems (5,000 PSI) and high-pressure systems (10,000 PSI). **NOTE: Each system has specific hose, and fluid requirements.**

The XRT **Westerbeke Combi System** is a two-stage multiple tool port hydraulic and AC power truck mounted system. The system is diesel driven, provides continuous flow, utilizes open center valves and is remotely mounted in the vehicle. When the selected tool or tools are engaged, the flow is diverted to the tool. At that point the tool will close steadily until it meets resistance. This causes the XRT low-pressure hydraulic pump to disengage, bypassing 75% of the total fluid and leaving 25% of the fluid to finish the work. When the tool is reversed, the flow resumes to the full flow to open the tool. Full flow and full pressure is provided at each power port via an engineered, dual level, pump system. The dual level system utilizes an individual pump for each level and an individual system for each power port.

XRT Westerbeke Combi System includes:

- Westerbeke Diesel Generator (7.6KW – 32KW)
- 3.5 Gallon Stainless Steel Reservoir tank with sight & temperature gauge
- XRT Pump with fittings (mounted on the backend of the generator)
- One Open Center Valve/Control Block assemblies per tool port ordered.
- Owners & Installation manuals.

Note: Pressure and return hose for installation are not included. These lengths are dictated by the distance of the control valve from the pump, and must be ordered separately.

Pump Identification & Hose Run to Open Center Valve

Engineering / Pre-installation Notes

Installation of the XRT System will be faster and easier if the following steps are completed before installing the system.

- Take care that all the components remain clean, organized, and handled carefully during the installation process.

Location of

Determine the location of

- Hydraulic reservoir/filter tank
- XRT Open Center Valves
- Tool hose reels

Open Center Valves / Control Blocks

- Identify the number of Open Center Valves that are delivered with your system. One XRT Open Center Valve with integral control block is required for each tool port on the system. Each valve is delivered with a stainless steel mounting plate.

Hose

Alert: XRT manufactures “5000 PSI Hurst Fluid Systems”, and “10,000 PSI Hydraulic Oil Systems”. Each system has specific hose and fluid requirements. **Refer to the recommended Hose Specifications and Fluid Specifications in this manual for XRT approved hose and fluid.** Hose, seal and total system contamination will occur if the wrong fluid is introduced into the system. **This type of installation error will void the XRT Warranty.** If you are not sure about what type of system you are installing, please contact XRT Power Systems (1-800-343-0480) for system confirmation.

- Measure the hose run for the entire system along the most accessible and shortest route for ease of installation and annual maintenance.
- Each power port for the system requires the following:
 - (2) Hoses in a run from the pump to the Control Blocks. These are the pressure hoses.
 - (1) Hose in a run from the Control Block to the return manifold at the filter on the reservoir tank. This is the return line.

- One set of “Lead-In Lines” from each XRT Open Center Valve to each hose reel. Often these lines are included with the Hose Reels.
- **Hose Lengths:** The Westerbeke Combi system requires connections inside the Stainless Steel shroud, and as a result of this, the total hose lengths required need to include the length hidden inside the shroud. It is important to order the correct lengths of each pressure and return line, as these are custom to each vehicle. Each tool port requires one low pressure high flow ¼” orange hose line (Pump Group A), one high pressure low flow ¼” black hose line (Pump Group B), and one 3/8” black return line.

Following is a picture of the Westerbeke Combi XRT Pumping system, with each Pump Group identified.

3 Tool Westerbeke Combi – Pump Group A - Hose Connection

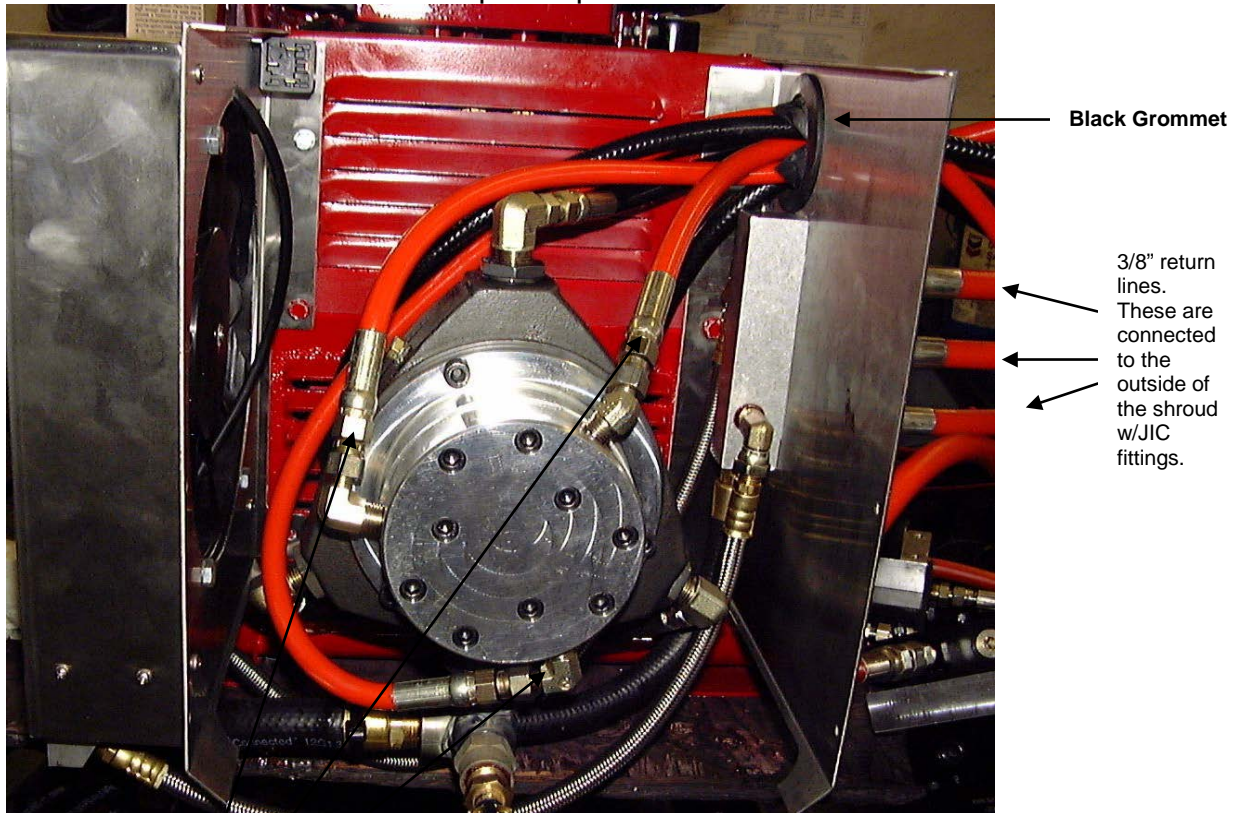

These Orange ¼” Pressure lines are designed for **Pump Group A**. We recommend Orange hose lines for these low pressure, high flow lines. They connect to the supplied JIC fittings. Refer to the Hose Specification Sheet for the recommended specifications.

Pump Group A – Hose length Guide

When determining the total length of each Group A ¼” hose. Measure the full run from the Valve Control Block to the Black Grommet on the face of the Shroud. Then add

- 12” to the total for closest fitting at 1:00 O'clock
- 16” to the total for the fitting at 10:00 O'clock
- 24” to the total for the fitting at 5:00 O'clock

If you need assistance please contact XRT Power Systems

3 Tool Westerbeke Combi – Pump Group B - Hose Connection

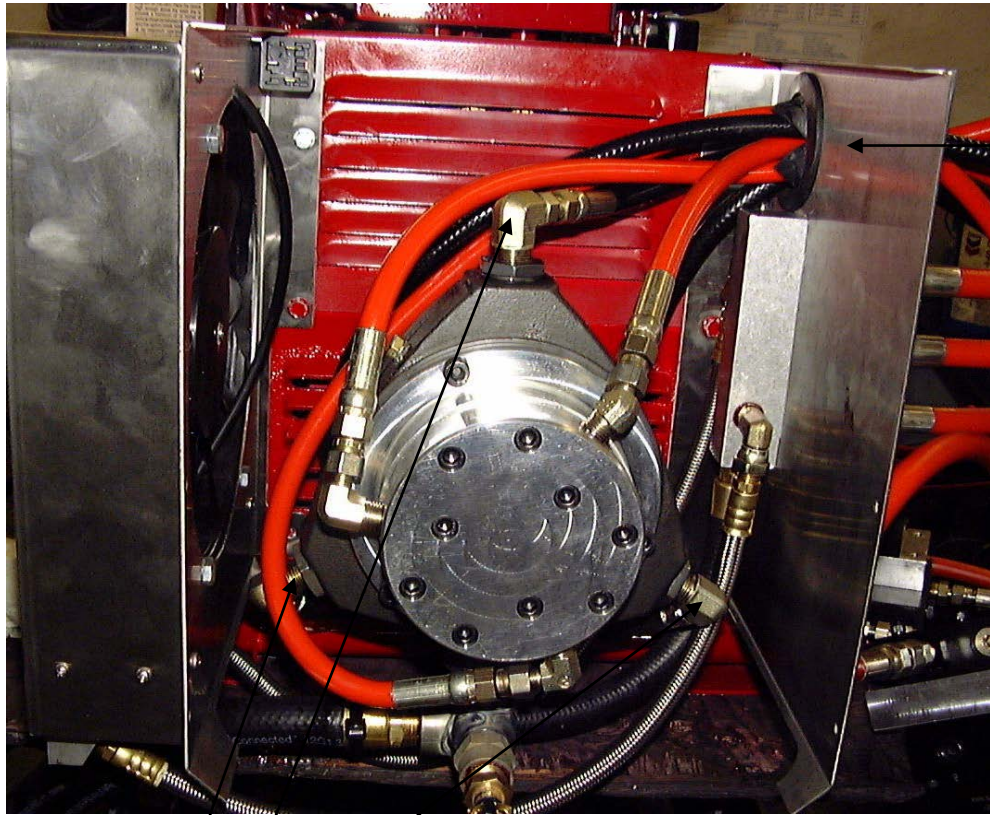

Black Grommet

These Black ¼" Pressure lines are designed for **Pump Group B**. We recommend Black hose lines for these high pressure, low flow lines. They connect to the supplied JIC fittings. Refer to the Hose Specification Sheet for the recommended specifications.

Pump Group B – Hose length Guide

When determining the total length of each Group B ¼" hose. Measure the full run from the Valve Control Block to the Black Grommet on the face of the Shroud. Then add

- 8" to the total for closest fitting at 12:00 O'clock
- 24" to the total for the fitting at 7:00 O'clock
- 28" to the total for the fitting at 4:00 O'clock

If you need assistance please contact XRT Power Systems

3 Tool Westerbeke Combi – 3/8" Return Line - Hose Connection
(As shown from the outside of the Stainless Steel Shroud).

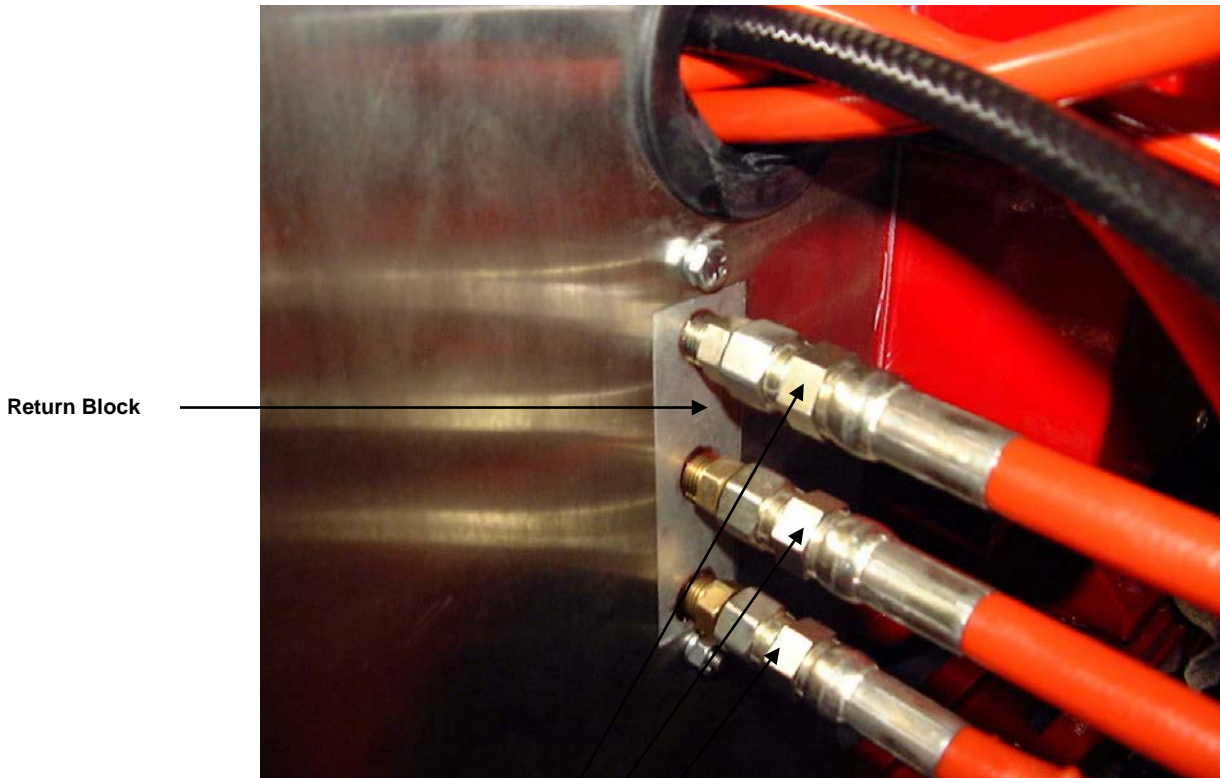

Return Lines on all XRT Systems are 3/8" in diameter. We recommend that they be Orange in color. They are connected directly to the supplied Male JIC fitting on the outside of the shroud. There is no need to add additional length to this overall measurement from the Open Center Valve/Control Block to the fitting shown above.

- **Installation Hint:**
- When two Open Center Valves are located in the same compartment, one return line may be used. A maximum of two Open Center Valves/Control blocks may share a mutual return line back to the Return Block on the Stainless Steel shroud. The Return Block is designed to accommodate three returns. If only one return line is used, it must always be connected to the top Connection point.

- Hoses are cut and fitted specifically for your vehicle. Be careful to allow for proper hose length for your installation. Should you decide to order the hose from a local supplier, please refer to the Hose Specification Sheet for proper hose selection.

Please contact **XRT Power Systems** at (781)-639-7125 to order the measured hose lengths, and for all engineering and installation questions.

Component Installation

If you have any technical questions before, during or after installation, please call the XRT Power Systems technical assistance line at 1-800-343-0480 ext. 126 (International Direct line 781-639-7126).

XRT Installation:

1. Install the XRT reservoir tank on the vehicle where it will be out of the way, but accessible for service requirements. Leave ample room underneath the filter for filter replacement, and enough room above the tank for fluid re-fill. **(See Photo 1)**

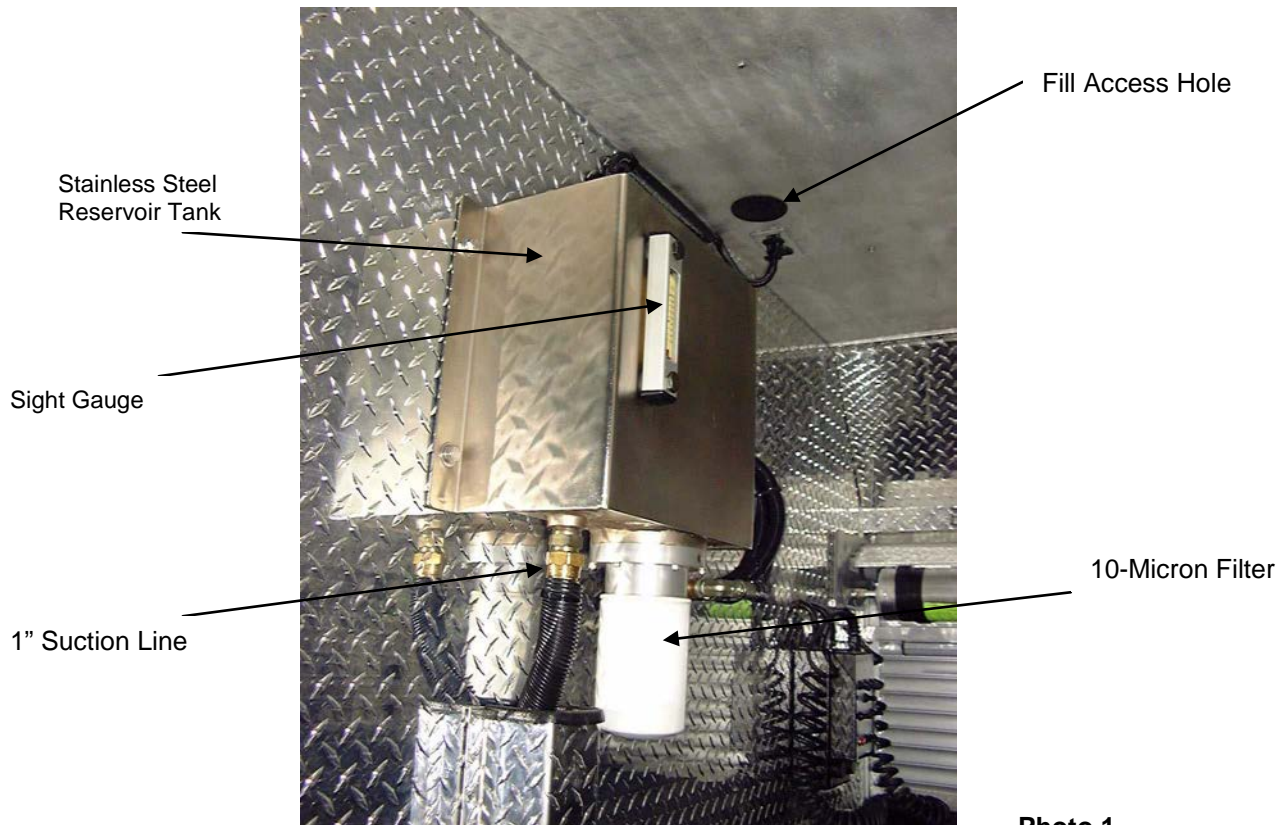

2. The XRT hydraulic pump is a gravity fed system. The reservoir tank must be installed at least 1 foot above the top of the pump, and no farther than 15 feet from the XRT pump.
3. The suction hose line used to supply oil to the XRT pump must be free from dips or loops in the line. It is recommended that this 3/4" line be

straight whenever possible. This will eliminate any air pockets within the line. This line should be trimmed to proper length if possible.

Connecting the Hose Lines:

4. Connect one end of the 3/4" Suction line to the bottom fitting supplied on the reservoir tank. The other end connects to the 3/4" fitting located at the bottom of the XRT Pump Assembly. (See picture below).
5. Connect one end of each 3/8" ID return line to one 3/8" fitting on the Control Block (on the back side of each **Open Center Valve Assembly**). Connect the other end of each 3/8" line to the fitting supplied on the Return block on the outside of the Stainless Steel Shroud on the Generator. (See picture on page 8.)

Pump Group "A", (See Photo 2) is the high volume, low-pressure pump group. Pictured here along with the assembly, it houses up to a total of three independent pumps. The orange hoses are attached to this pump.

The maximum pressure on this pump is 2,000 PSI. **See hose specifications.**



Pump Group “B” (See Photo 3) is the high pressure, low volume-cutting pump. Each radial tower is a pumping element. The black hoses are attached here. The hydraulic fluid used dictates the type and pressure rating of this hose.

The maximum operating pressure of this pump is 5000PSI if you have a Hurst System that uses Hurst Oil (Phosphate Esther) and 10,000PSI if you have a Hydraulic Oil System. **See hose specifications.**

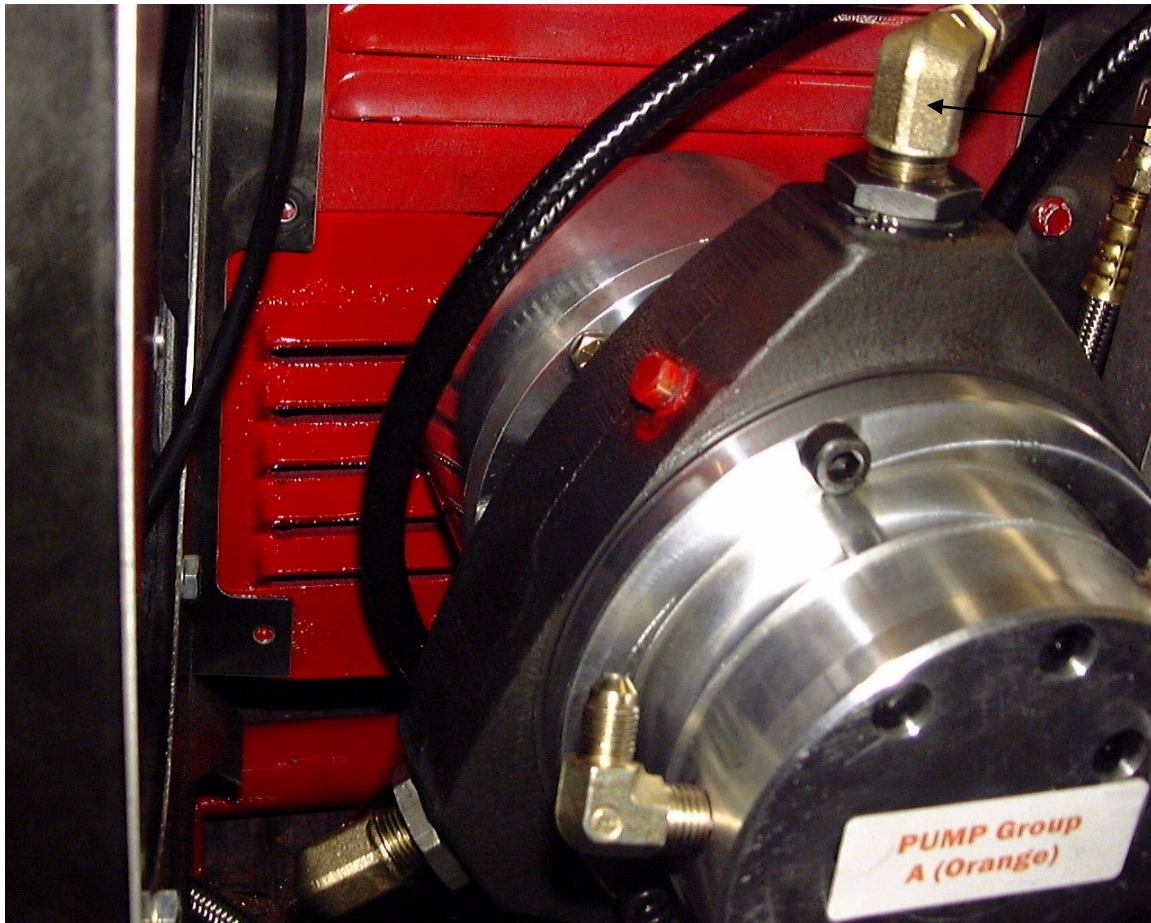

Pump Group B
High Pressure
1/4" Hose

Photo 3

Connecting the Open Center Valves / Control Blocks:

Each Open Center Valve / Control Block, (See Photo 5) has three hose connections. A label has been placed on the back of each block to help identify the connections.

NOTE: If the Valves that you are installing do not have the above-mentioned labels, please contact XRT Power Systems at 781-639-7125 for assistance. Otherwise refer to the picture below.

Connect the orange line to the Group "A" fittings. Connect the black line to the Group "B" fittings. Since all line hoses (black or orange) originate from independent pumps, each Control Block requires (1) Black and (1) Orange hose to complete the circuit. The third line connected to each control block is the 3/8 Return line mentioned above.

Pressure Adjustment:

All XRT systems are tested as a complete system before they are shipped. Pressures are pre-set, but adjustments are sometimes necessary.

Setting Pressure:

1. Connect a liquid filled pressure gauge that can handle up to 10,000 PSI on the pressure line at the end of the hose reel. This should be the male fitting.
2. Open the valve and let the pressure rise to maximum pressure.
3. Loosen Jamb nut on the High Pressure Adjuster (see picture below)
4. With a flat screwdriver, adjust slowly the pressure. Turn the screw until the desired pressure is set.
5. Re-lock the jamb nut. Close the valve, releasing the pressure.

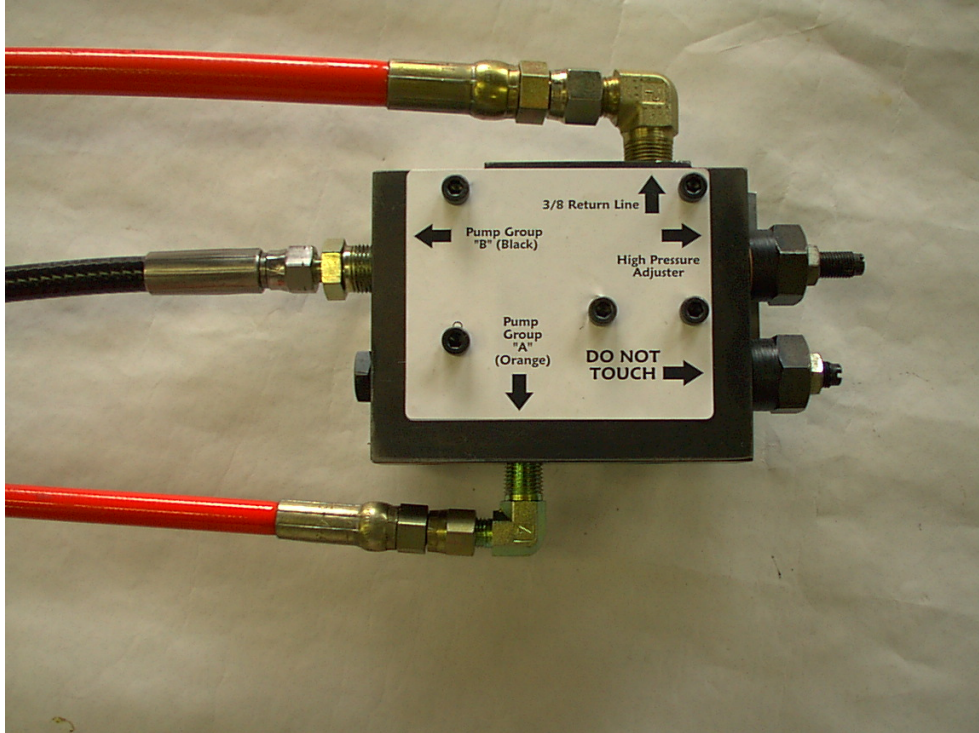

Photo 5 – Control Block Hook-up, Backside

Hose Specifications

Suction Line

Hydraulic Oil - 12G1x3/4" RI 12 CIT – Black Rubber hose (supplied)
Phosphate Ester - 12 PTFE with stainless steel over-braid (supplied)

Both ends on either hose style have #12 Female JIC Ends

Return Line

Return Line from control blocks to oil reservoir tank - Always use 3/8" for the return line.

Parker Parflex 518-C SAE-100R7 3/8" diameter

Both ends have 3/8" Female JIC fittings

Note: This hose can be used with both Hydraulic Oil and Phosphate Ester fluid. The pressure on the return line is approximately 30 PSI. XRT recommends 518C Hose to allow for sharper bends in the hose routing. This hose is rated at 4000 PSI. This was selected for hose stability going around corners.

Pump Group A – ¼" Low Pressure Line

Low pressure line from group "A" pumps to control blocks.

Parker Parflex 520N-4-100R8 x ¼" diameter (Working pressure of 5,000 PSI.)

The hose can be used for any fluid. The pressure on this circuit is approximately 2000 PSI. We suggest using orange color hose. Both ends to have ¼" Female JIC fittings.

Pump Group B – ¼" High Pressure Line – 5000 PSI

For All Hurst Fluid (Phosphate Esther Systems)

High Pressure lines from group "B" pumps to control blocks.

Parker Parflex 520N-4-100R8 x ¼" diameter with Female JIC fittings on both ends.

The pressure on this circuit is 5000-5200 PSI, for phosphate ester systems.

For Phosphate Ester Systems use the same spec as group "A" but use a different color, we suggest **black hose**

Pump Group B – ¼" High Pressure Line – 10,500 PSI

For all 10,500 PSI Hydraulic Oil Systems:

Parker Polyflex 2245N-04V00 ¼" diameter with Female JIC fitting on both ends.

The pressure on this circuit is approximately 10,000 PSI. We suggest **black hose**

XRT Oil Reservoir Tank

Location
Suction Hose
Filter
Cooler

The oil reservoir is a three-gallon tank. (See photo 1) Its features are:

1. Sight Gauge
2. Temperature gauge
3. 10 micron Filter
4. Vented oil fill

Location of the tank must be above the PTO, and in an area to be out of the way as much as possible. Remember that the filter needs to be changed and a bucket placed under it when changing the filter. The oil fill on top of the tank needs to be accessible as well, when replacing oil. The tank should be mounted to a robust compartment wall with 3/8 bolts. It is recommended that the walls around the hydraulic reservoir as well as the rescue tool compartment be outfitted with stainless steel veneer walls to prevent oil contamination, and to allow for easy cleaning.

For operations in EXTREME high ambient air temperature, a radiator (See photo 3) to cool the oil is available as an option. (Consult XRT Power Systems if you think you may require this option.)



Photo 1 - Oil Reservoir Tank



Open Center Valves

The Open Center Valves are used to stop flow of oil to the extrication tools this feature allows the tools to be interchanged without disengaging the Powerhouse PTO Pump from the engine.

The design features are:

1. 180-Degree Open Center Valve. (See Photo 1)
2. Four bolts attaching the valves to the control block thus allowing the valve to be removed and replaced without removing the control block from the truck.
3. **Open Center Valve** assemblies can be mounted anywhere on the vehicle.
4. **Stainless Steel** cover plate included with each valve.

Installation:

The Open Center Valve has two ports for hose connections. The 3/8" NPT ports will accommodate the Lead-In lines to the hose reel assembly. The ports are labeled "Tank" and "Pressure" on the side of the valve assembly.

Two square headed plugs are placed in these ports for dirt control during installation. Remove them and place proper fittings to connect the hose reels.

Note:

1. **Pressure** to the hose reel
2. **Tank** from the hose reel.

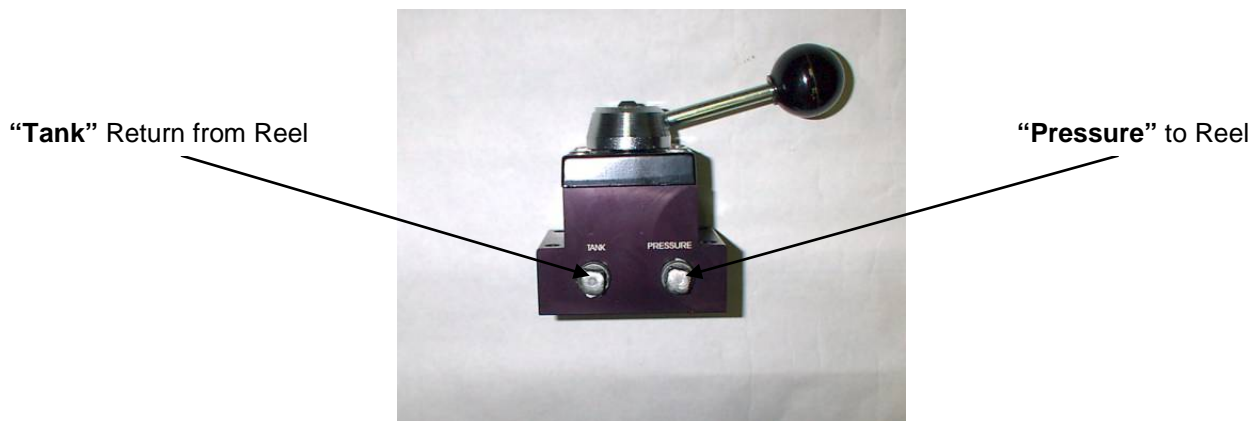

Both ports are 3/8 NPT

Caution: If reducer bushings are used, they must be hydraulic steel fittings, **water fittings or brass fittings are not acceptable.**

When mounting the Open Center Valve it is important that the two O-rings in between the Open Center Valve and mounting plate are not lost or displaced. A little grease on the O-rings will help keep them in place. (See Photo 3)



Photo 1 – Open Center Valve w/Mounting Plate



Front Bumper Two tool Installation

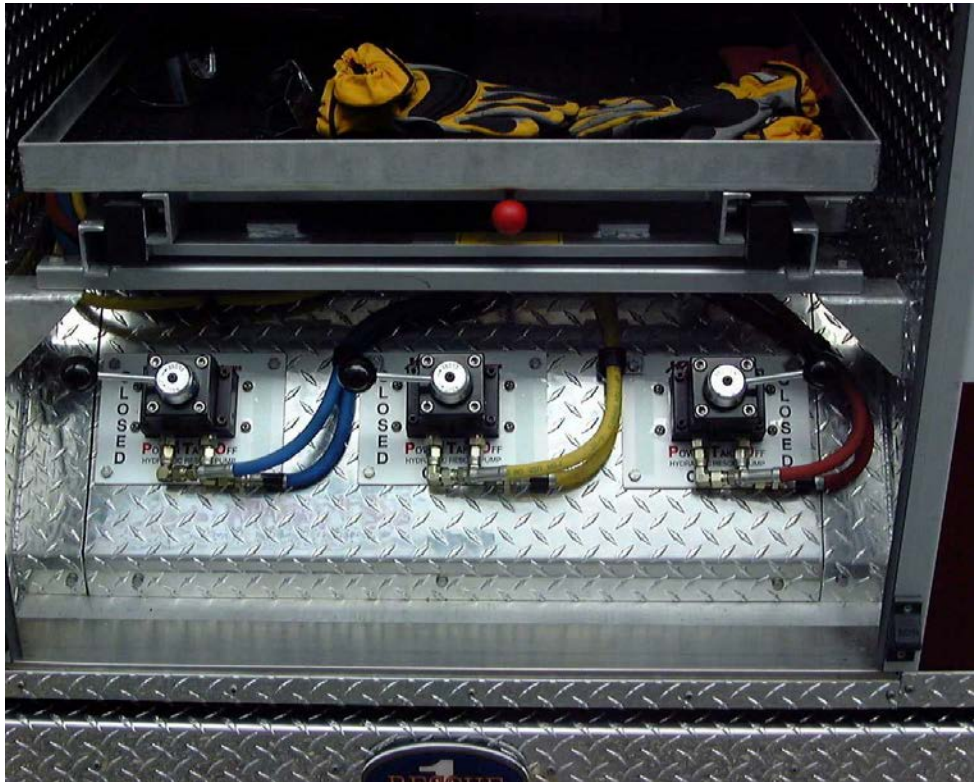

Three tool - Rear Compartment Installation

O-Rings

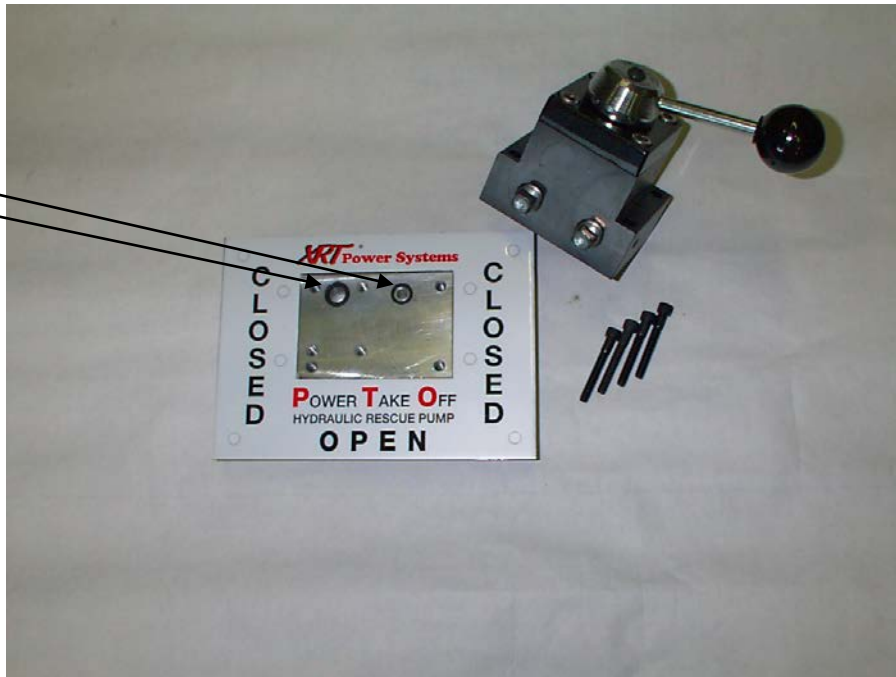

Photo 3 – Open Center Valve with Mounting Plate

ELECTRICAL SYSTEM

The oil is cooled via a DC electric fan and radiator, which is mounted on the back, non-service side of the *XRT*.

The fan power supply is from the positive post on the starter motor of the generator.

The circuit is protected by a 20 amp fuse, which can be found near the starter motor.

An oil probe, sensing inlet oil temperature, sends information to the switch gauge mounted on the front of the panel box. The oil temperature sensor is preset to 110° F. The fan will automatically come on when this temperature is reached.

When the generator is shut down, the fan will shut down regardless of the oil temperature, because the power for the relay is from the control box and it breaks the positive circuit of the fan relay. The fan relay is located on the radiator housing inside the *XRT* housing.

Be careful when working inside the housing. The fan blade is sharp; for added safety, remove the 20 amp fuse until your work is completed.

Note: On units built after April of 2000. The switch gauge has been replaced by an automatic switch sensor and therefore the external gauge has been eliminated.

Electrical Schematic

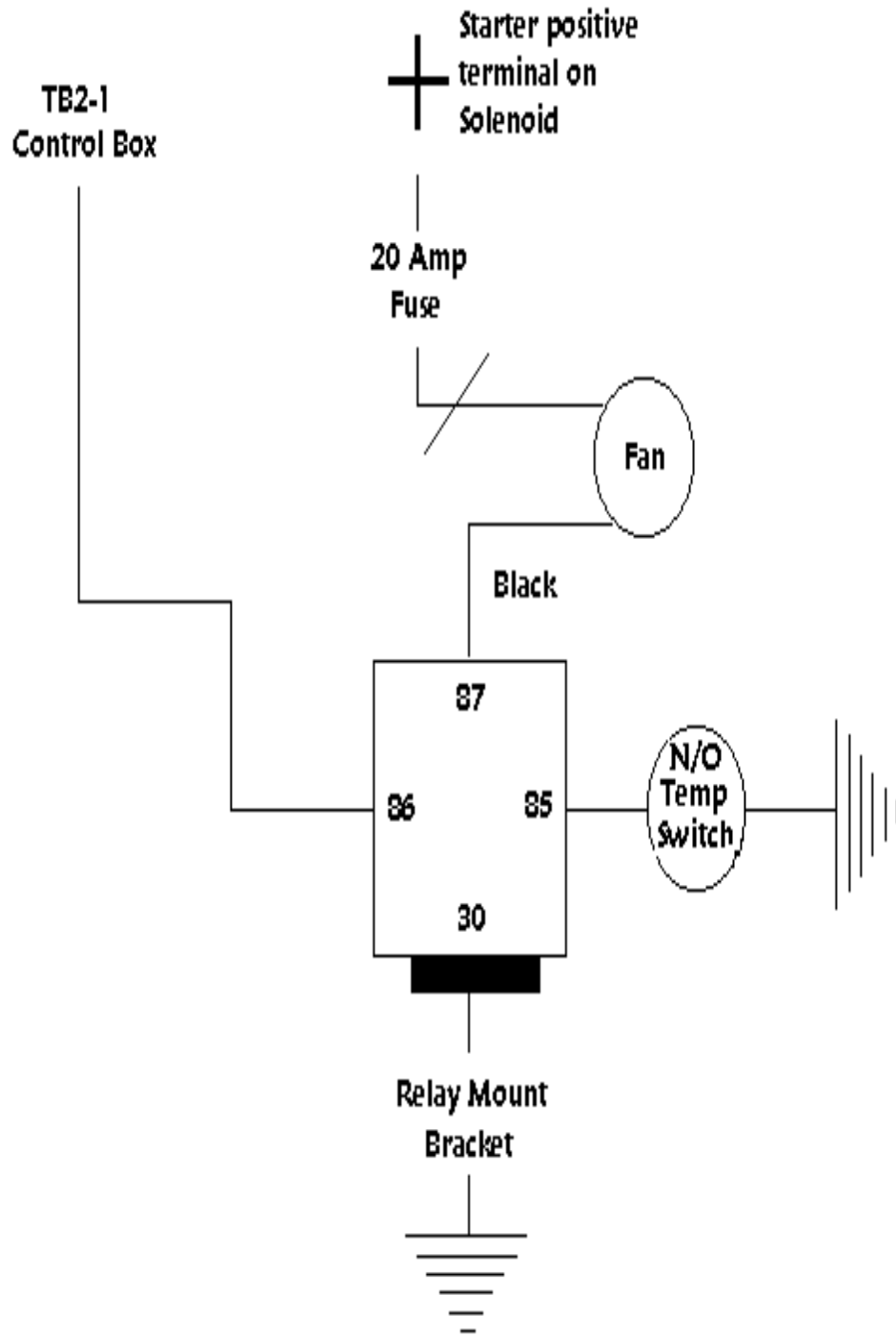

Installation Check List

- ❑ 1. Is the oil tank secure? Check its four mounting bolts.
- ❑ 2. The oil suction line to the XRT Pump is tight and secured level to frame of the truck.
- ❑ 3. The high-pressure oil lines from the XRT pump are tight and secured to the frame of the truck. Protective sleeves are used in high chafe areas.
- ❑ 4. The high pressure and return lines at the control blocks are tight and protected from chaffing.
- ❑ 5. Set all open center valves in the CLOSED position to prepare for test.
- ❑ 6. Partially fill the hydraulic oil tank for the XRT Combi system with the appropriate oil for the tool system. CAUTION! Do not fill system with more than (1) gallon before looking under truck for leaks. Fill tank.
- ❑ 7. Start generator and check for leaks. Run for 30 minutes before going to System Test.
- ❑ 8. Proceed with **System Test**.

**To operate extrication tools using the XRT Combi System:
The Generator must to on:**

1. With Generator On
2. Turn the Open Center Valve handle to the Open position.
3. **Tools are active.**
4. **When done using the tools turn the valve to either closed position.**

System Test

Once the system is operational, it is necessary to check all functions and make any calibrations.

1. Let the system run for approximately 30 minutes before initial test. This lets all pumps run before being put under a high-pressure load. When the PTO is engaged the diesel engine should automatically go to a preset elevated idle. This is the proper speed for the PTO to operate. Contact XRT Power Systems with any questions regarding PTO Ratio.
2. All **open center valves** are to be set in the closed position. One at a time connect, the hose reel ends together. Smoothly "open" the valve handle, this action will charge or bleed air from the hose reels. Repeat this for each valve and reel station.
3. Check fluid level in the tank and add as necessary. Filling one, two or three reels of hose will take some fluid.
4. Close one **open center valve** and disconnect the two hoses from each other at the end of the hose reel.
5. Connect a pressure gauge to the male fitting on the end of the hose reel.
6. Smoothly "open" the **open center valve**. The pressure gauge should immediately start to climb and go to the preset pressure for the system, if the pressure is too high or too low, then adjust the pressure on the **control block** and reseal. (See Control Block)
7. If the pressure does not climb when the **open center valve** is "opened" then check the hoses from the **open center valve** to the hose reels. The hoses are probably backwards. Swap the hoses and recheck.
8. Once all the **open center valve** stations are checked and calibrated, hook up the tools and check operation.
9. Make sure all warning and operation labels are in place, reservoir is topped off, **and open center valves** are in the **closed** position. Inspect for leaks again. Disengage the PTO. The engine speed will return to idle and the system test is done.

See Specifications for pressures and fluid requirements

TROUBLESHOOTING GUIDE

**All questions concerning the *XRT* should be directed to the Technical Service Department XRT Power Systems
1-800-343-0480.**

PROBLEM

REMEDY

All tools won't close or open.

1. Low oil or no oil

Fill with oil

Some tools won't close or open.

1. Selected wrong valve for
Desired tool

Turn on correct valve

All tools open, close and cut steady,
But slow.

1. Low pressure pump seized
or sheared.

Replace low pressure pump.

Hydraulic oil temperature exceeds 110°
and fan does not go on.

1. Fuse blown
2. Faulty relay
3. Switch gauge out of setting
4. Bad fan

Replace fuse
Replace relay if faulty
Reset to 115° F
Replace fan

Speed OK but tool(s) unable to cut.

1. Low on oil
2. Control block faulty
3. High pressure check valve
faulty

Fill with oil
Replace control block
Replace control block

MAINTENANCE GUIDE

Using the hour meter on the generator's engine is the best way to schedule service on the **XRT**.

When operating the **XRT** for the first time, run it for one hour checking carefully for any leaks.

Every 100 Hours Change the filter and oil every 100 hours or annually, whichever occurs first.

ANNUALLY

- Change the oil and the oil filter.
- Check for abrasions to the low- and high-pressure hoses. Replace as necessary.

EVERY 24 MONTHS

- Replace all of the hoses.
- Replace drive dampener.
- Test the low- and high-pressure relief valves.
- **Check for damaged or unreadable warning labels, replace as necessary**

For technical service, parts or questions, please call
Toll free, 1-800-343-0480

Installation Warning

XRT Combi system must be pressure checked before apparatus is put in service. Failure to check and confirm proper pressure to each tool port, may void warranty, and or cause failure during operation.



Certificate of Warranty For XRT Hydraulic Rescue Pump

Warranty:

- Each XRT hydraulic rescue pump is guaranteed against defects in material or workmanship from the original date of installation for two years or 2000 hours of use, whichever comes first, subject to the general limitations and exclusions set forth below.
- If it is determined, by an independent 3rd party representative of said tool manufacture, that the XRT pump system has caused damage to the hydraulic rescue tool that the system was built to power (as identified by the XRT serial number on the pump system), XRT Power Systems will repair, replace, or pay for repair or replacement of said tool, as set forth in tool manufactures warranty statement, subject to the general limitations and exclusions set forth below.

Warranty Terms:

The obligation of XRT Power Systems under this warranty include free replacement of the necessary parts and shipping costs to return the equipment to the user, provided the inspection of the equipment has proved that the parts were defective at the time of purchase or where improperly designed or manufactured. An authorized XRT Power Systems representative can only perform the warranty inspection, and the purchaser will pay the shipping cost to the repair center. Said warranty shall remain in effect only if (1) such goods are used normally and properly in accordance with XRT Power Systems instructions as to maintenance and operation, whether given orally or set forth in manuals furnished by XRT Power Systems, and (2) the purchaser gives prompt notice to XRT Power Systems of any such defects and preserves and turns over all allegedly defective goods, parts or items.

Exclusions:

This warranty covers all defects in material and workmanship except:
Any damage occurring during shipment of the goods (for which claims shall be presented to the carrier). Normal wear and tear parts and consumable parts and items including, o-ring replacement, hydraulic hose wear. Goods sold but not manufactured by XRT Power Systems, such as Parker Hannifin Hydraulic hose. Damage caused by repairs performed by persons other than authorized XRT service centers, or damage resulting from the use of parts other than genuine XRT parts. Damage as the result of improper or neglected reasonable maintenance.

Limitation of Damages:

XRT Power Systems obligation under this warranty is limited to repair and/or replacement, at XRT's option. If XRT Power Systems determines, in its sole and final discretion, that the nature of the defect precludes remedy by repair and or replacement, XRT Power Systems reserves the right to satisfy any warranty obligation by refunding the full purchase price, on return of all defective goods to XRT Power Systems, shipping cost prepaid. Any action of breach of warranty or other action must be commenced within one year after such action arises, except where applicable law prohibit any such time restriction on the bringing of such an action.



Dear XRT Power System Customer,

Congratulations on choosing XRT Power Systems & Westerbeke for your Fire Rescue apparatus. We value your business and will work with you from today on, to assure that our product surpasses your expectations in the field.

Whether you are receiving a Westerbeke diesel generator with XRT, or an XRT Powerhouse system, we would like you to be advised of the various phone/fax numbers as well as other way to communicate questions, and or problems to us. We are ready to provide technical support, and to fill your parts orders 24/7 and look forward to hearing from you on any given day.

Phone Numbers to remember:

Domestic & International: 781-631-3282

Sales Order Department: 781-639-7125

Parts Department: 781-631-3282

Technical Service: 781-639-7125

Warranty Department: 781-631-3282

Accounts Payable: 781-639-7124

General Questions: 781-639-7125

Fax Number: 781-639-1467

Email: info@xrtcombi.com

Web Site: www.xrtcombi.com

We hope you keep these numbers for future reference. Please remember, we are here to provide you the support and service you need, and when you need it. Thank you again for you support of our product, we look forward to hearing from you.